

# FOOD WARMERS: HOT TOPPING SINGLE WELL WARMERS, ROUND

Models FS, FSP & SBW



 FS 82500



FSP 82060



SBW 86810  
SIGNATURE TOUCH™

## BID DESCRIPTION

All stainless steel construction with a polished finish. An adjustable, precalibrated thermostat controls the 500 watt heating element. Temperature settings are marked on thermostat knob. Power is controlled with an ON/OFF rocker switch.

FS & FSP water bath models dispense from a stainless steel jar (94009) or #10 can (not included). SBW includes (3) 16 oz (.47 L) bottles.

FS comes complete with lift-off lid and 1 oz (30 mL), 10" (25.4 cm) ladle (82561).

The FSP features a stainless steel pump with rugged cast valve body and welded construction. Maximum stroke yields 1 oz (30 mL) with gauging collars to reduce yield in 1/8 oz (3.7 mL) increments.

The SBW, Signature Touch™ is an FS base with a drop-in bottle holder and (3) 16 oz (.47 L) high-density squeeze bottles. This model safely heats your plating toppings.

## STANDARD FEATURES

- Pump on FSP is designed to prevent loss of valve balls with a 1 oz (30 mL) stroke, adjustable in 1/8 ounce (3.7 mL) increments — allows for Portion Optimization™
- 500 watt heating element for reliable heating and holding
- Adjustable precalibrated thermostat for accurate heat control
- FS & FSP models dispense from Stainless Steel Jar or #10 can
- SBW squeeze bottle model provides safe heating while keeping your toppings handy for plating
- Signature Touch™ (SBW) includes (3) 16 oz (.47 L) squeeze bottles

## ACCESSORY ITEMS

- 3 qt (2.8 L) Stainless Steel Jar 94009
- Stainless Steel Jar Storage Lid 94008
- Squeeze Bottle, 16 oz (.47 L) 86809



ALSO AVAILABLE FOR EXPORT

SPECIFICATIONS ON REVERSE SIDE

The Boelter Companies, Inc.

# FOOD WARMERS: HOT TOPPING SINGLE WELL WARMERS, ROUND

Models FS, FSP & SBW

## FUDGE SERVER FS 82500

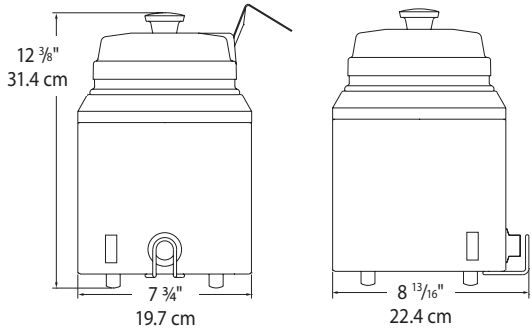

## FUDGE SERVER WITH PUMP FSP 82060

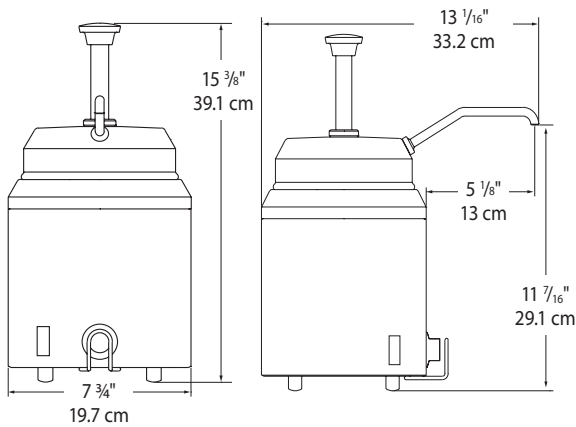

## SIGNATURE TOUCH™ TOPPING WARMER

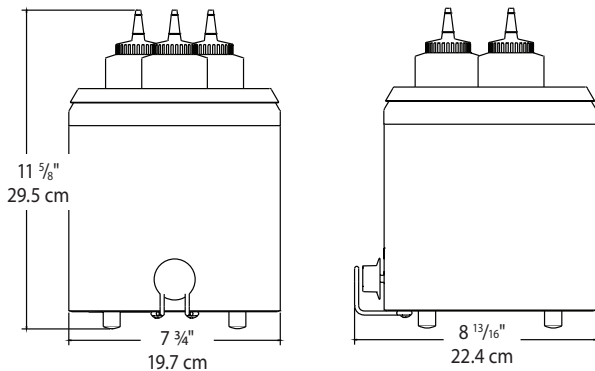

MODELS	FS 82500 	FSP 82060	SBW 86810
Height	12 3/8" 31.4 cm	15 3/8" 39.1 cm	11 5/8" 29.5 cm
Width	7 3/4" 19.7 cm	7 3/4" 19.7 cm	7 3/4" 19.7 cm
Depth	8 13/16" 22.4 cm	13 1/16" 33.2 cm	8 13/16" 22.4 cm
Capacity	3 qt 2.8 L	3 qt 2.8 L	48 oz 1.4 L
Weight	8 lb 3.6 kg	9 lb 4.1 kg	8 lb 3.6 kg
Electrical	120V, 60Hz, 500W, 4.2A, 72" (183 cm) cord set NEMA 5-15P, 15A, 125V PLUG		

FOB RICHFIELD, WISCONSIN 53076

NSF LISTED AS A RETHERMALIZATION UNIT TO ENSURE FOOD IS QUICKLY HEATED TO A SAFE TEMPERATURE BEFORE BACTERIA HAS AN OPPORTUNITY TO GROW. 

## CAD LIBRARY

Individual CAD images can be downloaded from our website. We are also a member of The KCL CADalog with more than 100 other manufacturers. Our complete collection of CAD files can be purchased through Kochman Consultants, Ltd. at [kclcad.com](http://kclcad.com).

## TWO YEAR WARRANTY

Server Products equipment is backed by a two-year limited warranty against defects in materials and workmanship. For a copy of our complete warranty statement, please refer to [server-products.com](http://server-products.com).